

T 2513 EN

Type 41-23 Universal Pressure Reducing Valve Self-operated Pressure Regulators · ANSI version



Application

Pressure regulators for set points from **0.75 to 400 psi (0.05 to 28 bar)** · Valves in **NPS ½ to 4 (DN 15 to 100)** · Pressure rating **Class 125 to 300 (PN 16 to 40)** · Suitable for water, gases and vapors up to **660 °F (350 °C)**

The valve **closes** when the downstream pressure rises

Special features

- Low-maintenance proportional regulators requiring no auxiliary energy
- Frictionless plug stem seal with stainless steel bellows
- Control line kit available for tapping the pressure directly at the valve body
- Wide set point range and convenient set point adjustment using a nut
- Exchangeable set point springs and actuator
- Spring-loaded, single-seated valve with upstream and downstream pressure balancing ¹⁾ by a stainless steel bellows
- Soft-seated plug for high shut-off requirements
- Standard low-noise plug
- All wetted parts free of non-ferrous metal

Versions

Pressure reducing valve to regulate the downstream pressure p_2 to the adjusted set point. The valve closes when the downstream pressure rises.

Type 41-23 · Standard version

Type 2412 Valve · Valve in **NPS ½ to 4 (DN 15 to 100)** · Plug with metal seal · Body made of either cast iron A126B, cast steel A216 WCC or cast stainless steel A351 CF8M

Type 2413 Actuator with EPDM rolling diaphragm

Version with additional features

Pressure reducing valve with increased safety · Actuator with leakage line connection and seal or two diaphragms and diaphragm rupture indicator

Steam pressure reducing valve with compensation chamber for steam up to 660 °F (350 °C)

Pressure reducing valve for low flow rates · Valve with micro-flow trim ($C_v = 0.0012$ to $0.05/K_{VS} = 0.001$ to 0.04) or special C_v/K_{VS} coefficients (restricted cross-sectional area of flow)

¹⁾ With $C_v \leq 3/K_{VS} \leq 2.5$: without balancing bellows

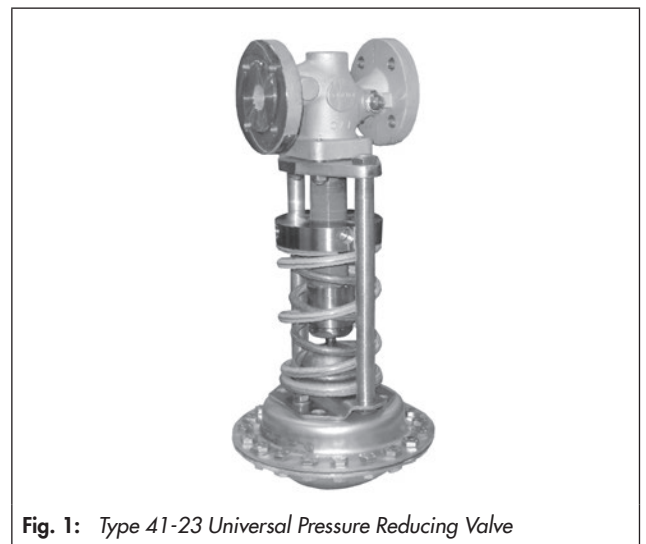

Fig. 1: Type 41-23 Universal Pressure Reducing Valve

Special versions

- Control line kit for tapping the pressure directly at the valve body (accessories)
- With internal parts made of FKM, e.g. for use with mineral oils
- EPDM diaphragm with PTFE protective facing
- Actuator for remote set point adjustment (autoclave control)
- Bellows actuator for valves NPS ½ to 4 (DN 15 to 100)
Set point ranges 30 to 85 psi, 75 to 145 psi, 145 to 320 psi, 300 to 400 psi (2 to 6 bar, 5 to 10 bar, 10 to 22 bar, 20 to 28 bar)
- Valve with flow divider ST 1 or ST 3 (NPS 2½ to 4/DN 65 to 100) for particularly low-noise operation with gases and vapors (see Data Sheet ▶ T 8081)
- Version entirely of stainless steel

- Stainless Cr steel seat and plug with PTFE soft seal (max. 440 °F/max. 220 °C) · With EPDM soft seal (max. 300 °F/max. 150 °C)
- Version for industrial gases
- Free of oil and grease for high-purity applications
- Stellite®-faced seat and plug for low-wear operation
- Wetted plastic parts conforming to FDA regulations (max. 140 °F/max. 60 °C)

Principle of operation (Fig. 2)

The medium flows through the valve (1) as indicated by the arrow. The position of the plug (3) determines the flow rate across the area released between plug and valve seat (2). The plug stem (5) with the plug (3) is connected to the actuator stem (11) of the actuator (10).

To control the pressure, the operating diaphragm (12) is tensioned by the set point springs (7) and the set point adjuster

(6) so that the valve is opened by the force of the set point springs when it is relieved of pressure ($p_1 = p_2$).

The downstream pressure p_2 to be controlled is tapped downstream of the valve and transmitted over the control line (14) to the operating diaphragm (12) where it is converted into a positioning force. This force is used to move the valve plug (3) according to the force of the set point spring (7).

The spring force is adjustable at the set point adjuster (6).

When the force resulting from the downstream pressure p_2 rises above the adjusted pressure set point, the valve closes proportionally to the change in pressure.

The fully balanced valve has a balancing bellows (4). The downstream pressure p_2 acts on the inside of the bellows, whereas the upstream pressure p_1 acts on the outside of the bellows. As a result, the forces produced by the upstream and downstream pressures acting on the plug are balanced out.

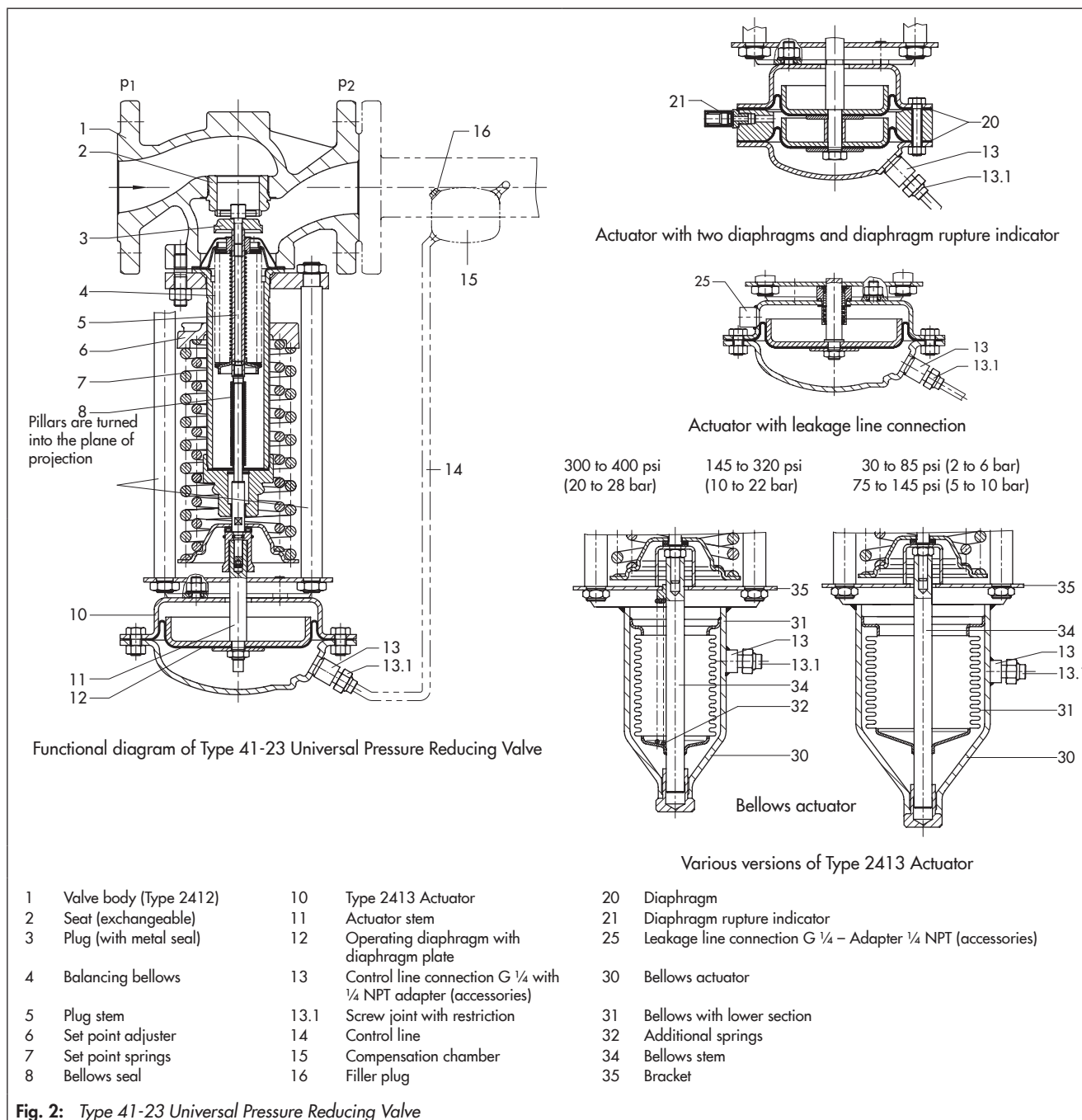

Fig. 2: Type 41-23 Universal Pressure Reducing Valve

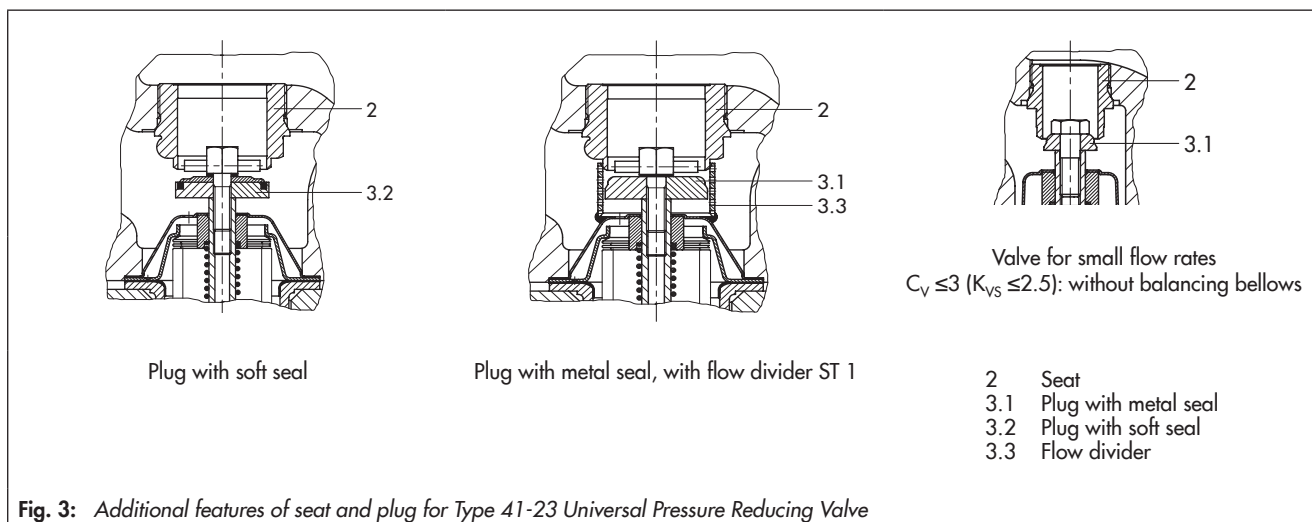

Fig. 3: Additional features of seat and plug for Type 41-23 Universal Pressure Reducing Valve

Table 1: Technical data · All pressures (gauge)

Valve		Type 2412		
Nominal pressure	Class	125, 150 or 300		
	PN	16, 25 or 40		
Valve size	NPS	½ to 2	2½ and 3	4
	DN	15 to 50	65 and 80	100
Max. permissible differential pressure	psi	360	290	230
	bar	25	20	16
Temperature ranges	See pressure-temperature diagram in ► T 2500			
	Valve plug	Metal seal: max. 660 °F (350 °C) · PTFE soft seal: max. 430 °F (220 °C) · EPDM, FKM soft seal: max. 300 °F (150 °C) · NBR soft seal: max. 175 °F (80 °C)		
Leakage class according to ANSI/FCI 70-2	Metal seal: Leakage class I (≤ 0.05 % of C_v/K_{vs} coefficient) Soft seal: Leakage class IV (≤ 0.01 % of C_v/K_{vs} coefficient)			
Compliance	CE ENEC			
Diaphragm actuator		Type 2413		
Set point ranges	0.75 to 3.5 psi · 1.5 to 8.5 psi · 3 to 17 psi · 10 to 35 psi ¹⁾ 30 to 75 psi · 65 to 145 psi · 115 to 230 psi			
	0.05 to 0.25 bar · 0.1 to 0.6 bar · 0.2 to 1.2 bar 0.8 to 2.5 bar ¹⁾ · 2 to 5 bar · 4.5 to 10 bar · 8 to 16 bar			
Max. permissible temperature	Gases 660 °F (350 °C), however, max. 175 °F (80 °C) at the actuator · Liquids 300 °F (150 °C), with compensation chamber max. 660 °F (350 °C) · Steam with compensation chamber max. 660 °F (350 °C)			
Bellows actuator		Type 2413		
Actuator area	5.1 sq. in (33 cm ²)		9.6 sq. in (62 cm ²)	
Set point ranges	145 to 320 psi (10 to 22 bar) 300 to 400 psi (20 to 28 bar)		30 to 85 psi (2 to 6 bar) 75 to 145 psi (5 to 10 bar)	

¹⁾ Version with actuator with two diaphragms: 15 to 35 psi/1 to 2.5 bar

Table 2: Max. perm. pressure at actuator

Set point ranges · Actuator with rolling diaphragm							Set point ranges · Bellows actuator			
0.75 to 3.5 psi (0.05 to 0.25 bar)	1.5 to 8.5 psi (0.1 to 0.6 bar)	3 to 17 psi (0.2 to 1.2 bar)	10 to 35 psi (0.8 to 2.5 bar)	30 to 75 psi (2 to 5 bar)	65 to 145 psi (4.5 to 10 bar)	115 to 230 psi (8 to 16 bar)	30 to 85 psi (2 to 6 bar)	75 to 145 psi (5 to 10 bar)	145 to 320 psi (10 to 22 bar)	300 to 400 psi (20 to 28 bar)
Max. perm. pressure above the set point adjusted at the actuator										
9 psi (0.6 bar)	9 psi (0.6 bar)	19 psi (1.3 bar)	36 psi (2.5 bar)	73 psi (5 bar)	145 psi (10 bar)	145 psi (10 bar)	94 psi (6.5 bar)	94 psi (6.5 bar)	116 psi (8 bar)	29 psi (2 bar)

Table 3: Materials · Material numbers according to ASTM and DIN EN

Valve	Type 2412		
Pressure rating	Class 125 (PN 16)	Class 150 (PN 25) Class 300 (PN 40)	Class 150 (PN 25) Class 300 (PN 40)
Max. permissible temperature	570 °F (300 °C)	660 °F (350 °C)	660 °F (350 °C)
Body	Cast iron A126B	Cast steel A216 WCC	Cast stainless steel A351 CF8M
Seat	CrNi steel		CrNiMo steel
Plug	CrNi steel		CrNiMo steel
Seal for soft-seated plug	PTFE with 15 % glass fiber · EPDM · NBR · FKM		
Guide bushing	Graphite		
Balancing bellows and bellows seal	Stainless steel 1.4571		
Actuator	Type 2413		
Diaphragm cases	Sheet steel DD11 (StW22) ¹⁾		
Diaphragm	EPDM with fabric insert ²⁾ · FKM for mineral oils · NBR · EPDM with PTFE protective facing		

¹⁾ In corrosion-resistant version (CrNi steel)

²⁾ Standard version; see Special versions for other diaphragms

Installation

Normally, the valve is installed with the actuator suspended downwards. Install pipelines horizontally with a slight downward slope on both sides of the valve for drainage of the condensate.

For further details on installation refer to Mounting and Operating Instructions

► EB 2512.

The direction of flow must match the arrow on the valve body.

- The control line must be adapted to match the onsite conditions and is not delivered with the valve. On customer request, a control line kit for pressure tapping directly at the valve body (see Accessories) is available.



Type 41-23 · Standard version

- **Control line kit** (optionally with or without compensation chamber) for direct attachment to the valve and actuator (pressure tapped directly at the valve body, for set points ≥ 12 psi/0.8 bar).
- **Compensation chamber** for condensation and to protect the operating diaphragm against extreme temperatures. A compensation chamber is required for liquids above 300 °F (150 °C) as well as for steam.

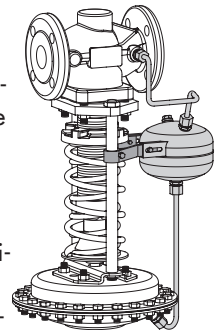

Type 41-23 · With control line and compensation chamber

For detailed information on accessories refer to Data Sheet ► T 2595

Accessories

Included in the scope of delivery:

- Screw joint with restriction for $\frac{3}{8}$ " control line.

To be ordered separately:

- Adapter G $\frac{1}{4}$ to $\frac{1}{4}$ NPT, various screw fittings.

Ordering text

Type 41-23 Universal Pressure Reducing Valve

Additional features ...

Valve size NPS (DN) ...

Class (PN) ..., body material ...

C_v coefficient (K_{VS} coefficient) ...

Set point range ... psi (bar)

Optionally, special version ..., accessories ... (► T 2595)

Dimensions (see Table 4)

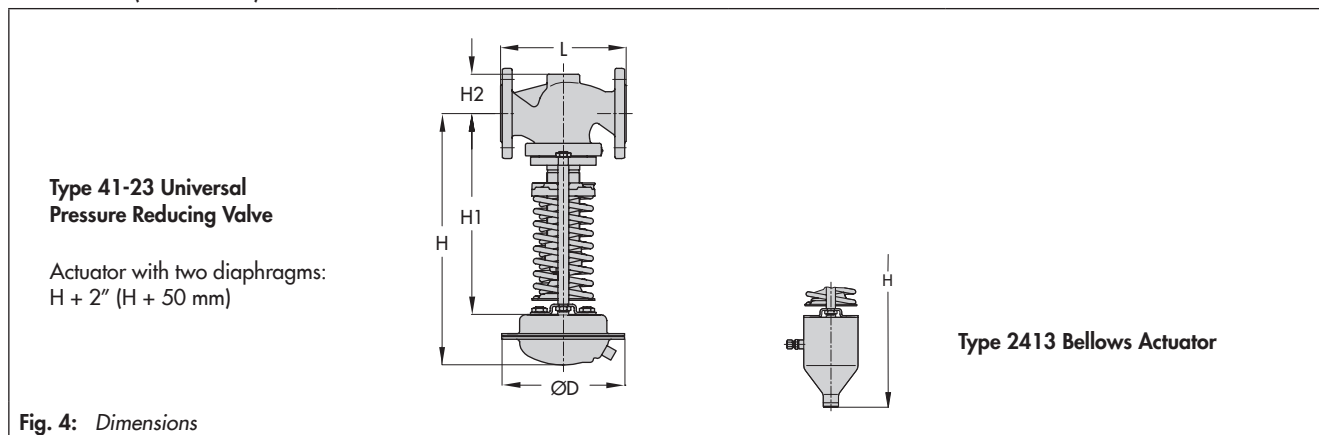

Fig. 4: Dimensions

Table 4: Dimensions and weights

Type 41-23 Universal Pressure Reducing Valve										
Valve size NPS (DN)			½ (15)	¾ (20)	1 (25)	1½ (40)	2 (50)	2½ (65)	3 (80)	4 (100)
Length L	Class 125	inch	–	–	7.25	8.75	10.0	10.87	11.75	13.87
		mm	–	–	184	222	254	276	298	352
	Class 150	inch	7.25	7.25	7.25	8.75	10.0	10.87	11.73	13.88
		mm	184	184	184	222	254	276	298	352
	Class 300	inch	7.50	7.63	7.75	9.25	10.50	11.50	12.50	14.50
		mm	190	194	197	235	267	292	318	368
Height H1	inch		13.19			15.35		20.08		20.67
	mm		335			390		510		525
Height H2	Cast steel	inch	1.73			2.83		3.86		4.65
		mm	44			72		98		118
	Forged steel	inch	2.1	–	2.76	3.62	3.86	–	5.05	–
		mm	53	–	70	92	98	–	128	–
Set point ranges		Dimension		Dimensions						
0.75 to 3.5	0.05 to 0.25	Height H		17.52" (445 mm)		19.69" (500 mm)		24.69" (627 mm)		25.59" (650)
		Actuator		ØD = 15.0" (380 mm), A = 100 in ² (640 cm ²)						
		Valve spring force		1750 N						
1.5 to 8.5	0.1 to 0.6	Height H		17.52" (445 mm)		19.69" (500 mm)		24.69" (627 mm)		25.59" (650)
		Actuator		ØD = 15.0" (380 mm), A = 100 in ² (640 cm ²)						
		Valve spring force		4400 N						
3 to 17	0.2 to 1.2	Height H		16.93" (430 mm)		18.90" (480 mm)		23.9" (607 mm)		25.0" (635)
		Actuator		ØD = 11.2" (285 mm), A = 50 in ² (320 cm ²)						
		Valve spring force		4400 N						
10 to 35 ²⁾	0.8 to 2.5 ²⁾	Height H		16.93" (430 mm)		19.09" (485 mm)		24.1" (612 mm)		25.0" (635)
		Actuator		ØD = 8.86" (225 mm), A = 25 in ² (160 cm ²)						
		Valve spring force		4400 N						
30 to 75	2 to 5	Height H		16.10" (410 mm)		18.31" (465 mm)		23.31" (592 mm)		24.21" (615)
		Actuator		ØD = 6.69" (170 mm), A = 12 in ² (80 cm ²)						
		Valve spring force		4400 N						
65 to 145	4.5 to 10	Height H		16.10" (410 mm)		18.31" (465 mm)		23.31" (592 mm)		24.21" (615)
		Actuator		ØD = 6.69" (170 mm), A = 6 in ² (40 cm ²)						
		Valve spring force		4400 N						
115 to 230	8 to 16	Height H		16.10" (410 mm)		18.31" (465 mm)		23.31" (592 mm)		24.21" (615)
		Actuator		ØD = 6.69" (170 mm), A = 6 in ² (40 cm ²)						
		Valve spring force		8000 N						
0.75 to 8.5	0.05 to 0.6	Weight ¹⁾ , approx.	lb	49.6	52	69.4	77.2	112.4	127.8	147.7
			kg	22.5	23.5	31.5	35	51	58	67
3 to 35	0.2 to 2.5	Weight ¹⁾ , approx.	lb	37.5	39.7	56.2	64	99.2	114.6	134.5
			kg	16	18	25.5	29	45	52	61
30 to 230	2 to 16	Weight ¹⁾ , approx.	lb	26.5	28.7	46.3	53	88.2	103.6	123.5
			kg	12	13	21	24	40	47	56
Bellows actuator										
30 to 85	2 to 6	Height H		21.65" (550 mm)		23.82" (605 mm)		28.82" (732 mm)		29.72" (755)
		Actuator		A = 9.6 in ² (62 cm ²)						
		Valve spring force		4400 N						
75 to 145	5 to 10	Height H		21.65" (550 mm)		23.82" (605 mm)		28.82" (732 mm)		29.72" (755)
		Actuator		A = 9.6 in ² (62 cm ²)						
		Valve spring force		8000 N						
145 to 320	10 to 22	Height H		21.06" (535 mm)		23.23" (590 mm)		28.23" (717 mm)		29.13" (740)
		Actuator		A = 5.1 in ² (33 cm ²)						
		Valve spring force		8000 N						
300 to 400	20 to 28	Height H		21.06" (535 mm)		23.23" (590 mm)		28.23" (717 mm)		29.13" (740)
		Actuator		A = 5.1 in ² (33 cm ²)						
		Valve spring force		8000 N						
A = 5.1 in ² (33 cm ²)	Weight ¹⁾ , approx.	lb	36	39	40	56	64	106	123	146
		kg	16.5	17.9	18	25.5	29	48	56	66
A = 9.6 in ² (62 cm ²)	Weight ¹⁾ , approx.	lb	46	47	49	65	73	119	143	165
		kg	20.9	21.5	22	29.5	33	54	65	75

¹⁾ Based on Class 150; +10 % for Class 300 ²⁾ Version with actuator with two diaphragms: 14.5 to 35 psi/1 to 2.5 bar

Table 5: C_V (K_{VS}) coefficients and x_{FZ} values · Terms for noise level calculation according to VDMA 24422, edition 1.89

Valve size NPS DN	Standard		x_{FZ}	Special version		x_{FZ}	With flow divider			
	C_V	K_{VS}		C_V	K_{VS}		C_V 1	K_{VS} 1	C_V 3	K_{VS} 3
½ 15				0.12 · 0.5 · 1.2	0.1 · 0.4 · 1	0.7 · 0.65 · 0.6				
				3	2.5	0.55				
	5	4	0.5				3.5	3		
¾ 20				0.12 · 0.5 · 1.2	0.1 · 0.4 · 1	0.7 · 0.65 · 0.6				
				3	2.5	0.55				
				5	4	0.5				
	7.5	6.3	0.45				6	5		
1 25				0.12 · 0.5 · 1.2	0.1 · 0.4 · 1	0.7 · 0.65 · 0.6				
				3	2.5	0.55				
	9.4	8	0.4	3 · 5 · 7.5	4 · 6.3	0.5 · 0.45	7.2	6		
1½ 40				7.5 · 9.4	6.3 · 8	0.45 · 0.4				
	23	20	0.4	20	16	0.4	17	15		
2 50				9.4	8	0.4	7.2	6		
	37	32	0.4	20 · 23	16 · 20	0.45 · 0.4	30	25		
2½ 65				23 · 37	20 · 32	0.4	30	25		
	60	50	0.4				45	38	30	25
3 80				37	32	0.4	30	25		
	94	80	0.35	60	50	0.4	70	60	46	40
4 100				60	50	0.4	45	38		
	145	125	0.35				110	95	70	60

1) With C_V 0.0012 to 0.05/ K_{VS} 0.001 to 0.04: valve with micro-trim (NPS ½ to 1/DN 15 to 25 only) without balancing bellows

Valve-specific correction terms

ΔL_G · For gases and vapors:

Values as specified in the diagram

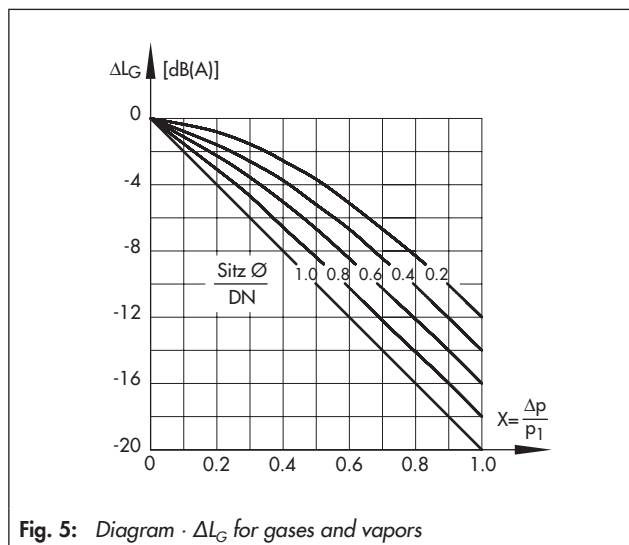

Fig. 5: Diagram · ΔL_G for gases and vapors

ΔL_F · For liquids:

$$\Delta L_F = -10 \cdot (x_F - x_{FZ}) \cdot y$$

$$\text{with } x_F = \frac{\Delta p}{p_1 - p_V} \text{ and } y = \frac{K_V}{K_{VS}}$$

Terms for control valve sizing according to IEC 60534, Parts 2-1 and 2-2:

$$F_L = 0.95, X_T = 0.75$$

x_{FZ} · Acoustical valve coefficient

C_V 1 (K_{VS} 1), C_V 3 (K_{VS} 3) · When a flow divider ST 1 or ST 3 is installed as a noise-reducing component · Flow characteristic differences between valves with and valves without flow dividers do not occur until the valve has passed through approx. 80 % of its travel range.