

## T 8053 EN

### Type 3252-1 and Type 3252-7 Pneumatic Control Valves Type 3252 High-pressure Valve

#### Application

Control valve especially designed for controlling low flow rates in process engineering

<b>Valve sizes</b>	<b>G ½ to G 1</b>	• <b>½ NPT to 1 NPT</b>
	<b>DN 15 to 25</b>	• <b>NPS ½ to 1</b>
<b>Pressure rating</b>	<b>PN 40 to 400</b>	• <b>Class 300 to 2500</b>
<b>Temperatures</b>	<b>-196 to +450 °C</b>	• <b>-325 to +842 °F</b>

Type 3252 High-pressure Valve with globe-style or angle-style valve body with:

- Type 3271 Pneumatic Actuator (Type 3252-1 Control Valve)
- Type 3277 Pneumatic Actuator (Type 3252-7 Control Valve)

#### Valve body

- Material 1.4404/A316 L
- G or NPT threaded connections, optionally welding ends or weld-on flanges

#### Valve plug

- Metal seal

The control valves, designed according to the modular assembly principle, can be equipped with various accessories: Positioners, limit switches, solenoid valves and other accessories according to IEC 60534-6 and NAMUR recommendation. Refer to Information Sheet ▶ T 8350 for more details.

#### Versions

**Standard version** designed as globe-style or angle-style valve body with V-ring PTFE packing suitable for temperatures from -10 to 220 °C (15 to 430 °F) · Pressure rating PN 40 to 400 or Class 300 to 2500 · Female thread G ½, G ¾, G 1 or ½ NPT, ¾ NPT, 1 NPT · Body material 1.4404/A316 L

- **Type 3252-1** · Valve with Type 3271-5 Pneumatic Actuator (120 cm<sup>2</sup>) or Type 3271 Pneumatic Actuator (350 cm<sup>2</sup>)
- **Type 3252-7** (Fig. 1) · Valve with Type 3277-5 Pneumatic Actuator (120 cm<sup>2</sup>) or Type 3277 Pneumatic Actuator (350 cm<sup>2</sup>) for integral positioner attachment

#### Further versions

- **Welding ends** · DN 15, 20, 25 or NPS ½, ¾, 1
- **Flanges** · DN 15, 20, 25 or NPS ½, ¾, 1
- **Male thread** · On request



**Fig. 1:** Type 3252-7 High-pressure Valve with Type 3767 Positioner

- **Insulating section** · For temperatures from -196 to +450 °C (-325 to +842 °F)
- **Bellows seal** · For PN 40 to 400 or Class 150 to 2500
- **Special valve body materials** · On request
- **Adjustable packing**
- **Heating jacket** · Details on request

### Principle of operation

The medium flows through the valve in the direction indicated by the arrow. The valve plug position determines the cross-sectional area between the seat and plug. The plug stem is connected to the actuator stem by the stem connector and sealed with a self-adjusting packing. To comply with stricter environmental emissions requirements, the valve can be equipped with a multiple-walled metal bellows.

### Fail-safe position

Depending on how the springs are arranged in the pneumatic actuator (► T 8310-1), the valve has two different fail-safe positions effective upon air supply failure.

#### Actuator stem extends (fail-close)

The valve is closed upon air supply failure.

#### Actuator stem retracts (fail-open)

The valve is opened upon air supply failure.

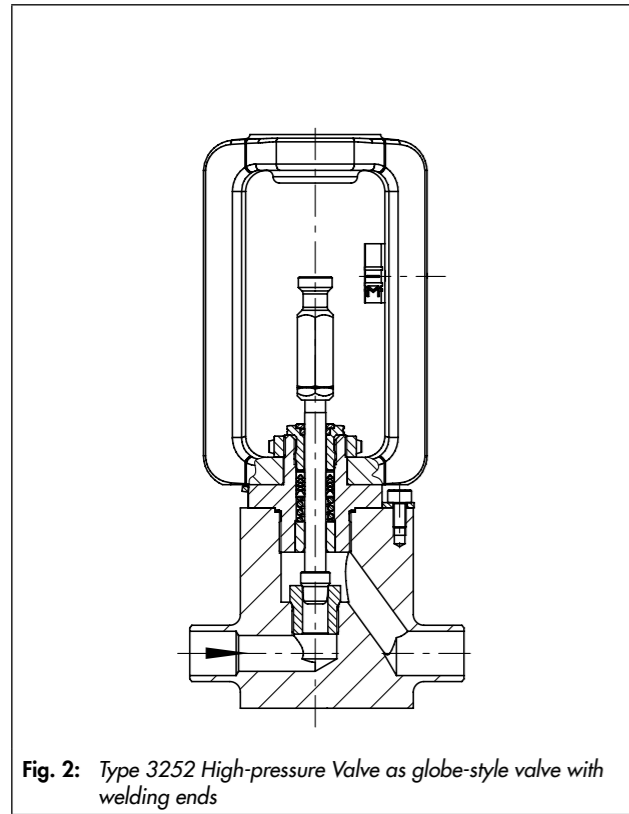

Fig. 2: Type 3252 High-pressure Valve as globe-style valve with welding ends

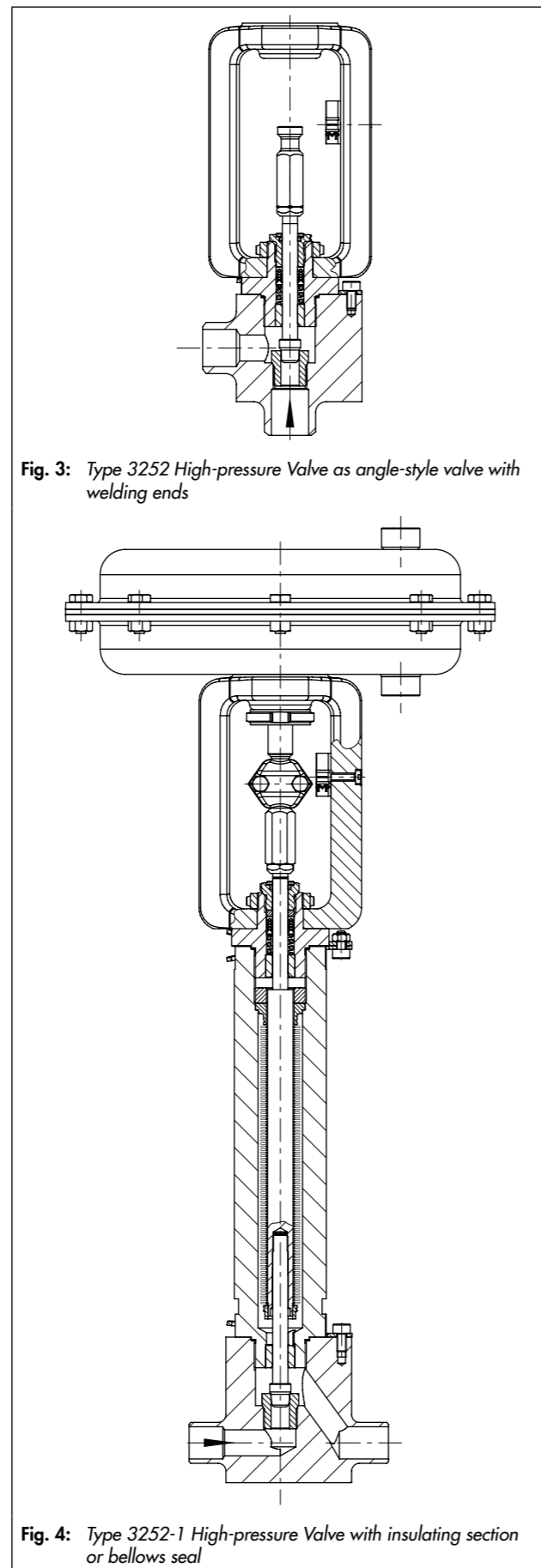

Fig. 3: Type 3252 High-pressure Valve as angle-style valve with welding ends

Fig. 4: Type 3252-1 High-pressure Valve with insulating section or bellows seal

Table 1: Technical data for Type 3252

Connection	Female thread	Welding ends	Weld-on flanges
Valve size	G 1/2, G 3/4, G 1 1/2 NPT, 3/4 NPT, 1 NPT	DIN 15, 20, 25 NPS 1/2, 3/4, 1	DIN 15, 20, 25 NPS 1/2, 3/4, 1
Pressure rating	PN 40 to 400 or Class 300 to 2500		
Seat/plug seal	Metal seal or high-performance metal seal Soft seal for $K_{VS}$ 0.1 and higher up to an operating pressure of 50 bar		
Characteristic	Equal percentage · Linear · Quick opening		
Rangeability	50:1		
Compliance	EAC		
<b>Temperature ranges</b>			
Body without insulating section	-10 to +220 °C (14 to 428 °F)		
Body with Insulating section	-50 to +450 °C (-58 to +842 °F)		
Body with Long insulating section	-196 to +450 °C (-325 to +842 °F)		
Body with Bellows seal	-50 to +450 °C (-58 to +842 °F)		
Leakage class according to DIN EN 1349	Metal seal: IV · High-performance metal seal: V <sup>1)</sup> · Soft seal: VI		

<sup>1)</sup> Leakage class V for temperatures below -50 °C (-58 °F) on request

Table 2: Materials

Standard version	
Valve body	1.4404/A316 L · Other materials on request
Valve bonnet (wetted parts)	1.4404/A316 L
Seat and plug	1.4404/A316 L (seat with Stellite facing and plug made of solid Stellite available)
Packing	V-ring packing, PTFE with carbon
Body gasket	1.4404/A316 L
<b>Insulating section</b>	1.4404/A316 L
<b>Bellows seal</b>	
Intermediate piece	1.4404/A316 L
Metal bellows	1.4571/A316 Ti

Table 3: Available  $C_V$  and  $K_{VS}$  coefficients

Terms for control valve sizing according to IEC 60534, Parts 2-1 and 2-2:  $F_L = 0.95$ ,  $X_T = 0.75$

Table 3.1: Overview

$K_{VS}$	0.1	0.16	0.25	0.4	0.63	1	1.6	2.5	4
$C_V$	0.12	0.2	0.3	0.5	0.75	1.2	2	3	5
Seat Ø	3 <sup>1)</sup>			6			12		14
Travel	7.5								
Plug stem Ø	10								

<sup>1)</sup> Available for version with insulating section or bellows seal (on request)

Table 3.2: Valve sizes and associated  $K_{VS}$  and  $C_V$  coefficients

$K_{VS}$	0.1	0.16	0.25	0.4	0.63	1	1.6	2.5	4
$C_V$	0.12	0.2	0.3	0.5	0.75	1.2	2	3	5
DN	NPS								
15	1/2	•	•	•	•	•			
20	3/4	•	•	•	•	•	•	•	
25	1	•	•	•	•	•	•	•	•

**Table 4:** Permissible differential pressures for versions without bellows seal · All pressures stated in bar

**Table 4.1:** Fail-close valve

Bench range		0.2 to 1.0	0.4 to 2.0	1.4 to 2.3	2.1 to 3.3	
Operating range with 7.5 mm travel and actuator area of	120 cm <sup>2</sup>	0.6 to 1.0	1.2 to 2.0	1.85 to 2.3	2.7 to 3.3	
	350 cm <sup>2</sup>	0.8 to 1.2	1.6 to 2.4			
Required supply pressure		bar	1.4	2.6	2.5	3.5
Valve size	K <sub>VS</sub>	Actuator [cm <sup>2</sup> ]	Δp when p <sub>2</sub> = 0 bar			
DN 15 to 25 NPS ½ to 1	0.1 to 1.0	120	50	120	200	300
		350	250	400	–	–
	1.6 · 2.5	120	35	85	140	210
		350	175	350	400	–
	4	120	25	60	100	150
		350	130	270	310	400

**Table 4.2:** Fail-open valve

Bench range		0.2 to 1.0				
Operating range with 7.5 mm travel and actuator area of	120 cm <sup>2</sup>	0.2 to 0.6				
	350 cm <sup>2</sup>					
Required supply pressure		bar	1.4	2.5	3.5	
Valve size	K <sub>VS</sub>	Actuator [cm <sup>2</sup> ]	Δp when p <sub>2</sub> = 0 bar			
DN 15 to 25	0.1 to 1.0	120	90	230	375	
		350	300	400	–	
	1.6 · 2.5	120	60	165	260	
		350	210	400	–	
	4	120	45	120	190	
		350	150	375	400	

**Table 5:** Permissible differential pressures for versions with bellows seal · All pressures stated in bar

**Table 5.1:** Fail-close valve

Bench range	120/350 cm <sup>2</sup>	0.2 to 1.0	0.4 to 2.0	1.4 to 2.3	2.1 to 3.3	
Operating range with 7.5 mm travel and actuator area of	120 cm <sup>2</sup>	0.6 to 1.0	1.2 to 2.0	1.85 to 2.3	2.7 to 3.3	
	350 cm <sup>2</sup>	0.8 to 1.2	1.6 to 2.4			
Bench range	700 cm <sup>2</sup>			0.6 to 3.0	0.6 to 3.0	
Operating range with 7.5 mm travel and actuator area of	700 cm <sup>2</sup>	–		2.4 to 3.0	3.0 to 3.6	
Required supply pressure		bar	1.4	2.6	2.5	3.5
Valve size	K <sub>VS</sub>	Actuator [cm <sup>2</sup> ]	Δp when p <sub>2</sub> = 0 bar			
DN 15 to 25	0.1 to 1.0	120	–	15	30	50
		350	45	100	120	185
		700	–	–	325	400
	1.6 · 2.5	120	–	15	30	50
		350	45	100	120	185
		700	–	–	325	400
	4	120	–	15	30	50
		350	45	100	120	185
		700	–	–	300	400

**Table 5.2:** Fail-open valve

Bench range		0.2 to 1.0			
Operating range with 7.5 mm travel and actuator area of	120 cm <sup>2</sup>	0.2 to 0.6			
	350 cm <sup>2</sup>				
	700 cm <sup>2</sup>				
Required supply pressure		bar	1.4	2.5	3.5
Valve size	K <sub>VS</sub>	Actuator [cm <sup>2</sup> ]	Δp when p <sub>2</sub> = 0 bar		
DN 15 to 25	0.1 to 1.0	120	6	39	68
		350	52	145	230
		700	153	340	400
	1.6 · 2.5	120	–	36	62
		350	47	130	210
		700	140	310	400
	4	120	–	32	56
		350	42	120	190
		700	125	284	400

**Table 6:** Dimensions and weights for Type 3252 Valve (globe-style body)

Valve	Standard	DIN			ANSI			
	DN	15	20	25	NPS	½	¾	1
Length L with female thread	PN 40 to 400	130			Class 300 to 2500	130		
Length L with welding ends	PN 40 to 400	130	130 (PN 40 only)	130	Class 300 to 2500	130		
Length L with flanges	PN 40	210	210	230	Class 300	190	194	197
	PN 63 to 160	210	–	230	Class 600	203	206	210
	PN 250 to 400	–	–	260	Class 900/1500	216	229	254
–		–	–	Class 2500	264	273	308	
B	PN 40 to 400	70	70	70	Class 300 to 2500	70	70	70
H1		246	246	246		246	246	246
H2		26	26	26		26	26	26
<b>Weights in kg for globe valve including yoke</b>								
With female thread	PN 40 to 400	8.5			Class 300 to 2500	On request		
With welding ends		6.5						
With flanges	PN 400	13	–	19.5	Class 2500	12.5	13.5	16.5

**Table 7: Dimensions and weights for Type 3252 Valve (angle-style body)**

Valve	Standard	DIN			ANSI			
	DN	15	20	25	NPS	½	¾	1
Length L with female thread	PN 40 to 400	60			Class 300 to 2500	60		
Length L with welding ends	PN 40 to 400	57	57 (PN 40 only)	57	Class 300 to 2500	57		
Length L with flanges	PN 40	90	95	100	Class 300	95 <sup>1)</sup>	97 <sup>1)</sup>	98 <sup>1)</sup>
	PN 63 to 160	105	–	115	Class 600	102 <sup>1)</sup>	103 <sup>1)</sup>	105 <sup>1)</sup>
	PN 250 to 400	115	–	130	Class 900/1500 Class 2500	108 132	114 136	127 154
B	PN 40 to 400	70			Class 300 to 2500	70		
H1		212				212		
<b>Weights in kg for angle valve including yoke</b>								
With female thread	PN 40 to 400	7.5			Class 300 to 2500	On request		
With welding ends		5.5						
With flanges	PN 400	12	–	18.5	Class 2500	11.5	12.5	15.5

<sup>2)</sup> Special length

**Table 8: Dimensions in mm for version with insulating section or bellows seal**

Globe valve	DN	15	20	25	NPS	½	¾	1
H4 with insulating section	PN 40 to 400	433			Class 300 to 2500	433		
H4 with bellows seal	PN 40 to 160	433			Class 300 to 900	433		
	PN 250	501			Class 1500	501		
	PN 400	606			Class 2500	606		
Angle valve	DN	15	20	25	NPS	½	¾	1
H4 with insulating section	PN 40 to 400	400			Class 300 to 2500	400		
H4 with bellows seal	PN 40 to 160	400			Class 300 to 900	400		
	PN 250	468			Class 1500	468		
	PN 400	572			Class 2500	572		
Weights	DN	15	20	25	NPS	½	¾	1
Bellows seal (additional kg)	PN 40/160	3.5			Class 300 to 2500	On request		
	PN 250	5.0						
	PN 400	6.5						

**Table 9: Dimensions in mm and weights in kg for actuators**

Actuator area	cm <sup>2</sup>	120	350	700	
Diaphragm ØD	mm	168	280	390	
H <sup>1)</sup>	mm	69	82	199	
H3 <sup>2)</sup>	mm	110	110	190	
H5	Type 3277	mm	88	101	101
Thread	Type 3271	M30 x 1.5			
	Type 3277	M30 x 1.5			
a	Type 3271	G ½ (½ NPT)	G ¾ (¾ NPT)	G ¾ (¾ NPT)	
a2	Type 3277	–	G ¾	G ¾	

Actuator area	cm <sup>2</sup>	120	350	700
Weight of Type 3271	Without handwheel	2,5	8	22
	With handwheel	4	13	27
Weight of Type 3277	Without handwheel	3,2	12	26
	With handwheel	4,5	17	31

<sup>1)</sup> Height with welded-on lifting eyelet or height of eyebolt according to DIN 580. Height of the swivel lifting hook may differ. Actuators up to 350 cm<sup>2</sup> without lifting eyelet  
<sup>2)</sup> Minimum clearance required to remove the actuator

**Dimensions for Type 3252 Valve (angle-style and globe-style bodies)**

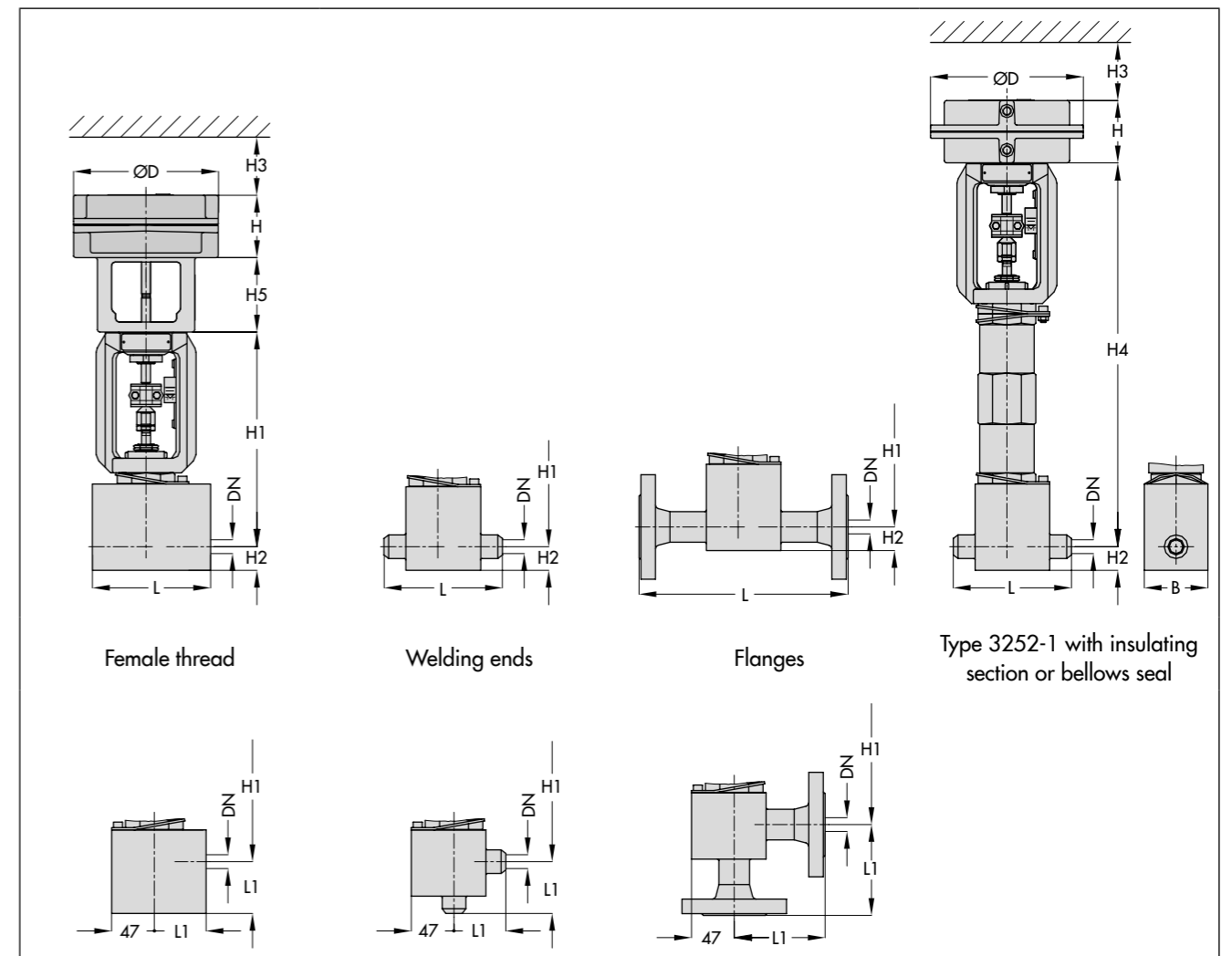

**Order specifications:**

Type 3252 Valve	Globe or angle valve
Valve size and pressure rating	According to DIN or ANSI
Type of end connections	Female thread G or NPT/flanges/welding ends
Characteristic	Equal percentage or linear
Direction of flow	Flow-to-open or flow-to-close
Pneumatic actuator	Type 3271 or Type 3277 (Data Sheet ► T 8310-1)
Fail-safe position	Fail-close or fail-open
Process medium	Density in kg/m <sup>3</sup> and temperature in °C
Max. flow rate	kg/h or m <sup>3</sup> /h in standard or operating state
Pressure	p <sub>1</sub> and p <sub>2</sub> in bar (absolute pressure p <sub>abs</sub> ) (with minimum, normal and maximum flow rate)
Valve accessories	Positioner and/or limit switch

Note: The temperature limits for DIN and ANSI versions are not directly converted temperatures.